

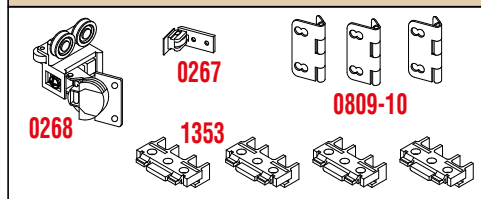

Sistemi scorrevoli per armadi / Folding systems for furniture

KIT 0268-267



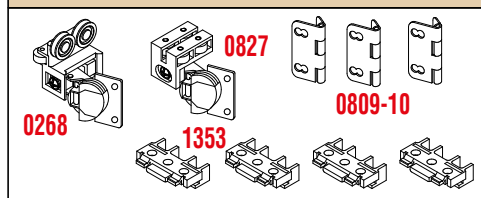

KIT 0268-827



Legenda KIT / Kit Legend

0267	Rotella inferiore <i>Lower wheel</i>
0268	Carrello superiore con cerniera <i>Upper truck with hinge</i>
0809/10	Cerniera simmetrica - asimmetrica con bussole <i>Symmetrical - Asymmetric hinge with bushes</i>
0827	Guida inferiore con cerniera <i>Lower runner with hinge</i>
1353	Supporto a scatto per ART.0271 <i>Clip for ART.0271</i>

Legenda altri componenti Legend other items

0823		Profilo alluminio inferiore <i>Lower aluminium profile</i>
0271		Profilo alluminio superiore <i>Upper aluminium profile</i>

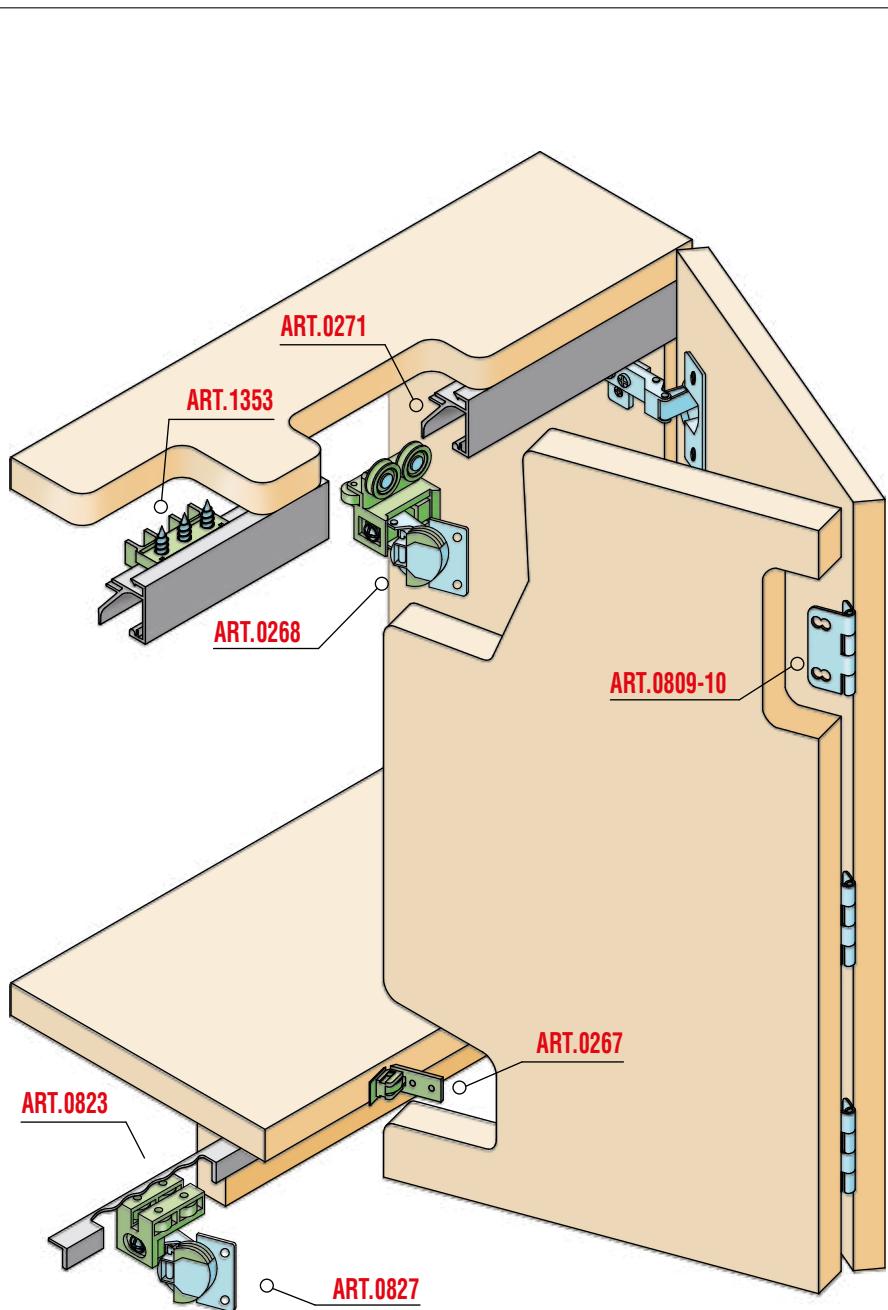

Sezione verticale / Vertical section

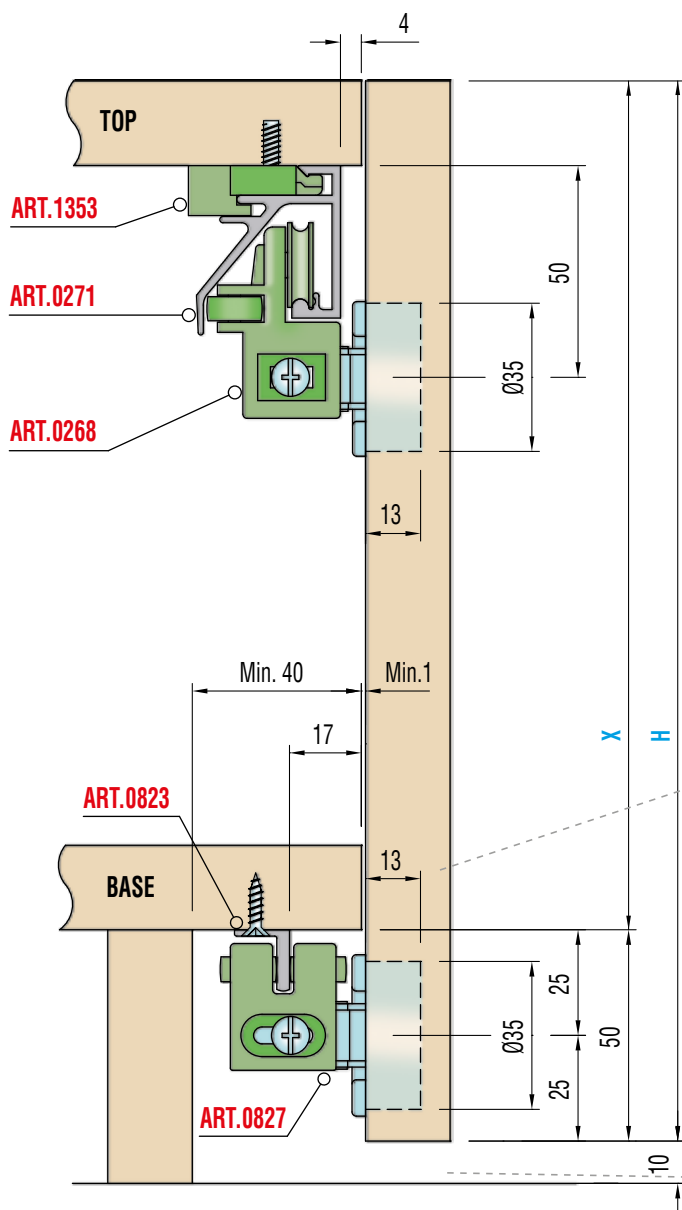

DIMENSIONI ANTE DIMENSIONS OF THE DOORS

Altezza Height	max. 2600 mm.
Larghezza Width	max. 500 mm.
Spessore Thickness	min. 16 mm. - max. 30 mm.

Montaggio profilo art.0271 Fitting Of Profile Art. 0271

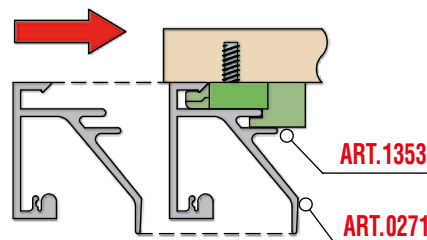

Variante Special version

Con guida inferiore Art.0267
With lower runner Art.0267

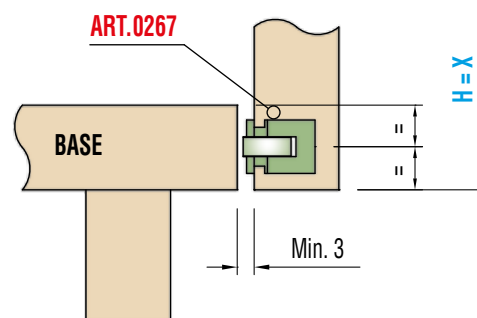

$$H = X + 50$$

Posizione di montaggio cerniere centrali art.0809-10

Assembling position of the centre hinges art.0809-10

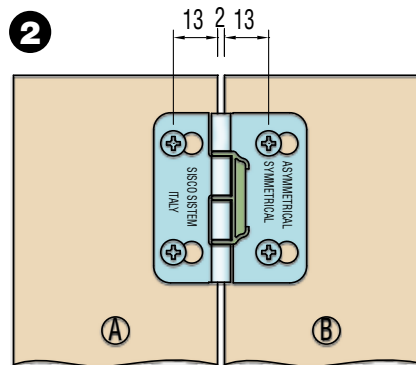
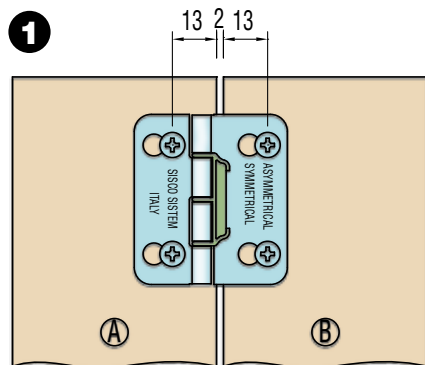

Per il corretto funzionamento del sistema, Vi consigliamo l'uso di cerniere laterali con apertura a 110°, in abbinamento alle cerniere centrali, ART.0809-10, montate in modo asimmetrico (1). Se invece utilizzate cerniere laterali con apertura a 90°, montate le cerniere centrali, ART.0809-10, in modo simmetrico (2).

To ensure a proper functioning of the system, we suggest you to use side hinges with 110° opening, along with centre hinges, ART.0809-10, asymmetrically fitted (1). If you use side hinges with 90° opening, fit centre hinges, ART.0809-10, symmetrically (2).



Sistemi scorrevoli per armadi / Folding systems for furniture

Schema foratura ante / Doors drilling

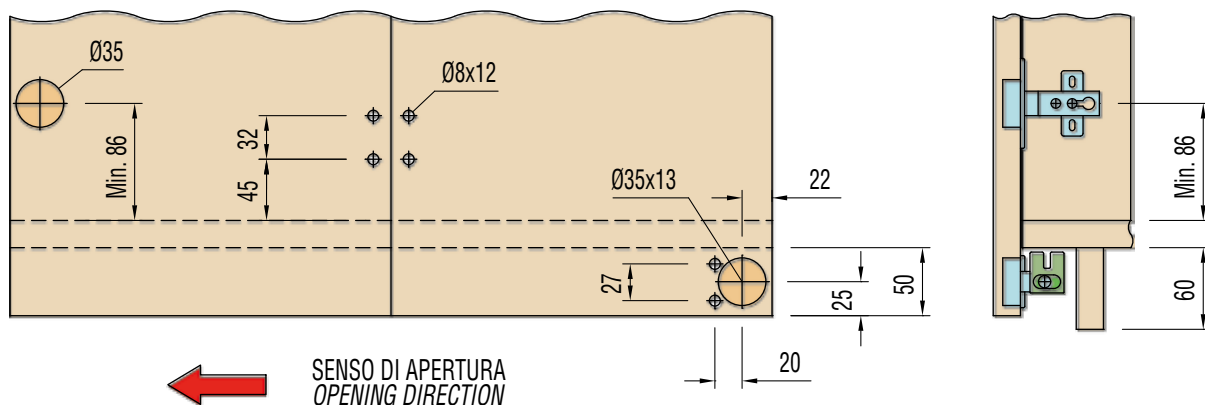
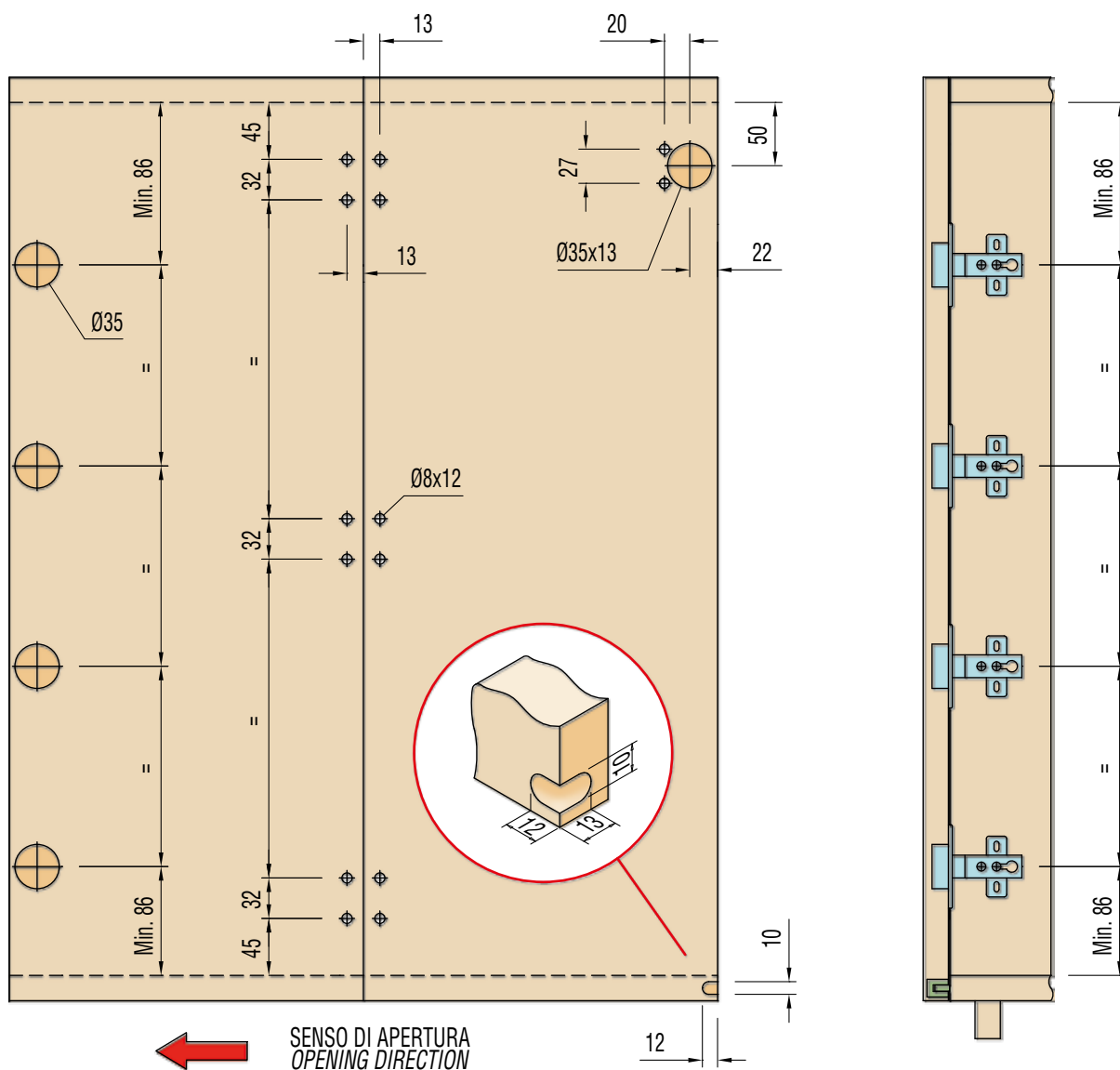

Il peso delle ante deve essere sostenuto dalle cerniere laterali montate sulla spalla del mobile e non dal carrello superiore, che ha la sola funzione di guida. Consultate il vostro fornitore per determinare quante cerniere devono essere montate sulla spalla del mobile, in funzione delle dimensioni e del peso delle vostre ante.

The weight of the doors is born by the side hinges fitted to the wardrobe side, not by the upper truck which only functions as a guide.
Turn to your supplier for the quantity of hinges which must be fitted to the wardrobe side, depending on the dimensions and weight of your doors.

Schema di montaggio / Assembling

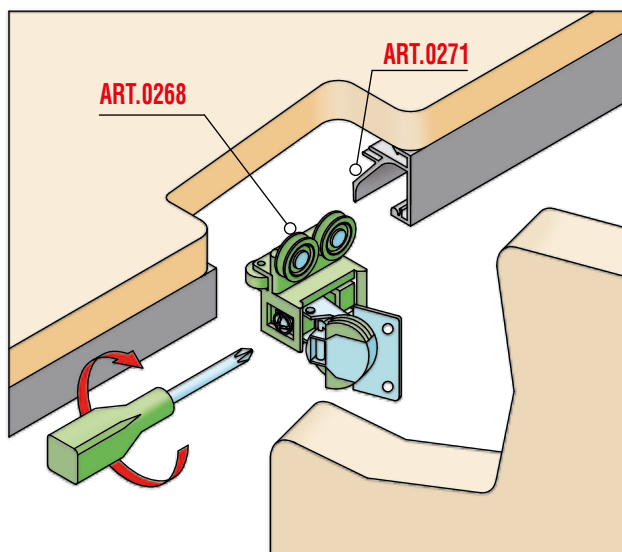
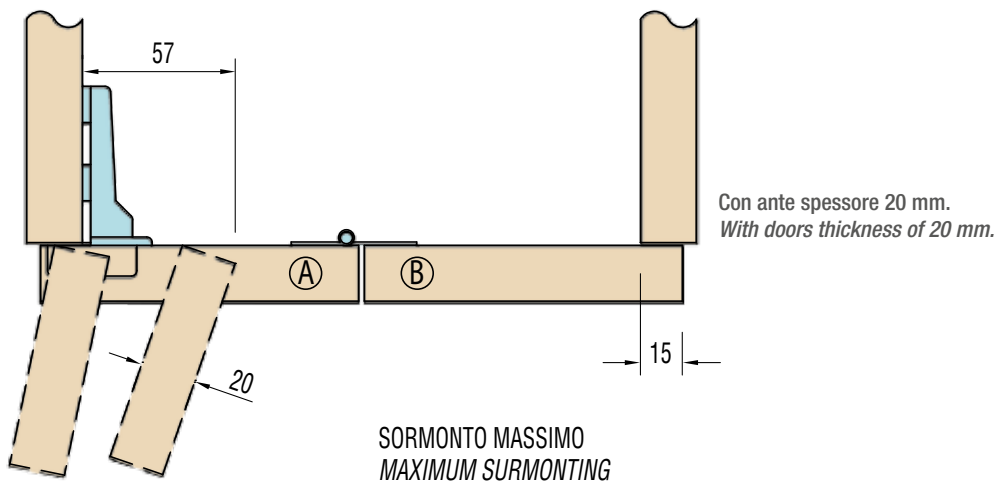
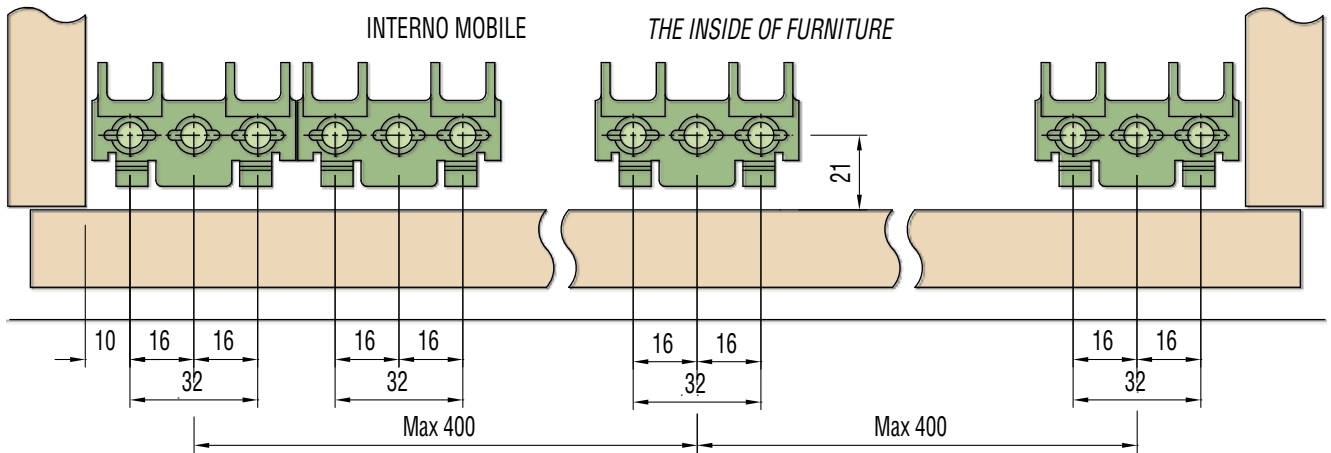

Inserire il carrello superiore (ART. 0268) nel relativo binario guida (ART. 0271). Posizionare il binario nell'interno del mobile e successivamente fissare il carrello all'apposita cerniera (come da disegno).

Insert the upper truck (ART. 0268) in its truck (ART. 0271). Place the truck inside the furniture piece, then fasten the truck with the suitable hinge (see drawing)